

BRINGING EFFICIENCY TO HEAT TRANSFER



PLATE & FRAME FOR MAXIMUM EFFICIENCY

OPTIMUM PERFORMANCE IS A PROMISE TRANTER, INC., HAS BEEN FULFILLING FOR MANY DECADES WITH SUPERCHANGER® PLATE & FRAME HEAT EXCHANGERS. TRANTER SPECIALIZES IN PROVIDING HEAT TRANSFER SOLUTIONS IN ALL INDUSTRIES. OUR COMPLETE ENGINEERING AND MANUFACTURING EXPERTISE BRINGS YOU EQUIPMENT THAT MEETS THE HIGHEST STANDARDS OF DESIGN EXCELLENCE AND QUALITY WORKMANSHIP.

GOT INCREASED PRODUCTION AND BUDGET DEMANDS?

GET EFFICIENT, COST-EFFECTIVE SOLUTIONS WITH TRANTER HEAT TRANSFER TECHNOLOGY.

EFFICIENT AND RELIABLE HEAT TRANSFER FOR EVERY INDUSTRY

The SUPERCHANGER® is Tranter's trademarked gasketed plate heat exchanger. SUPERCHANGER® are ubiquitous, and they can be found operating across the globe today on offshore oil platforms, in the basements and on the rooftops of casinos, hospitals, and universities, in chemical plants, refineries, gas processing facilities, amusement parks, data centers, and breweries. You will see them in the utility rooms of geothermal pool resorts, in power plants, automobile factories, steel mills, elementary schools, and in about half of all ethanol plants in North America. These are just a few of the many applications that utilize SUPERCHANGER®.

The plates and gaskets for Tranter's SUPERCHANGER® are designed by Tranter engineers at our R&D headquarters in Houston, Texas. They are designed to achieve specific goals such as higher pressure ratings, more efficient heat transfer with lower pressure drop, and to handle tough media such as streams with a high particulate load. Our engineering team is constantly checking the market for new trends that may require different designs, and Tranter regularly launches new plate designs.

Tranter's sizing software is also fully designed by Tranter engineers and is certified by AHRI. Once designed and pressed, Tranter plates are extensively tested for heat transfer and pressure-drop characteristics to obtain a base of empirical data which is fed into the algorithms to

create sizings. When Tranter submits a performance data sheet, it is generated by that same sizing program and that sheet represents a performance guarantee that Tranter stands behind. Tranter performance details are not based on theoretical data, but on the empirical data gathered during testing.

WORLD-CLASS MANUFACTURING, SUPERIOR TESTING, AND SERVICING

ISO 9001 Certification

Tranter is ISO certified, adhering to the highest standards in designing, manufacturing, and testing SUPERCHANGER® plate & frame heat exchangers.

Tranter offers world-class service for all plate heat exchangers, including its own. We maintain a network of Tranter service centers around the globe, including five located in North America. These service centers are also ISO 9001 certified, and provide complete refurbishment services for heat exchangers and plate packs. In addition, they are staffed with field-service technicians ready to dispatch to your location to provide on-site service.

Finally, Tranter's Innovation Center in Houston is a unique lab where creative design ideas are imagined and verified, and heat exchangers can be examined under a variety of hot and cold full-flow testing conditions with a variety of flow media. Even customer testing requests can be accommodated. *Expect more from Tranter, the heat transfer people.*

AHRI CERTIFIED PLATE SERIES

GT SERIES (AT - AHRI Certified)

The GT series features a deeper gasket groove for higher pressures – up to 450 psig, a shallow draw depth for tight temperature approaches, and an inside-out halo alignment system. The series is specifically designed for HVAC or other tight-temperature-approach applications. Models available in 6" in and higher port-sizes. The plate series features HydroFit™ -Variable draw depth to help distribute flow from port to heat transfer area and the The Omniflex™ plate pattern – A patented Tranter design enabling high energy efficiency. The unique plate pattern induces high turbulence and enhanced heat transfer rates, with low pressure drop.

GL SERIES (AL – AHRI Certified)

GL series plates have herringbone style embossings that are available across a large span of angles, making them versatile for a wide range of applications. This includes super high flow applications requiring port sizes up to 18".

GCP SERIES (ACP - AHRI certified)

GC plates feature a deeper-than-standard draw depth and a longer pitch, maximizing the disengagement space and making them ideal for low pressure drop or viscous fluid applications. Additionally, they are optimal for steam applications and can deliver high heat transfer rates at low pressure drops.

GXD SERIES (AXD - AHRI certified)

GXD plate technology uses two asymmetrical plate patterns and a neutral gasket plane (meaning either side can be the gasket side) to create six possible flow channel configurations. That means each stream sees a different channel geometry, which is why these plates are superior performers when the flows are unbalanced and the allowable pressure drops are reasonably close.

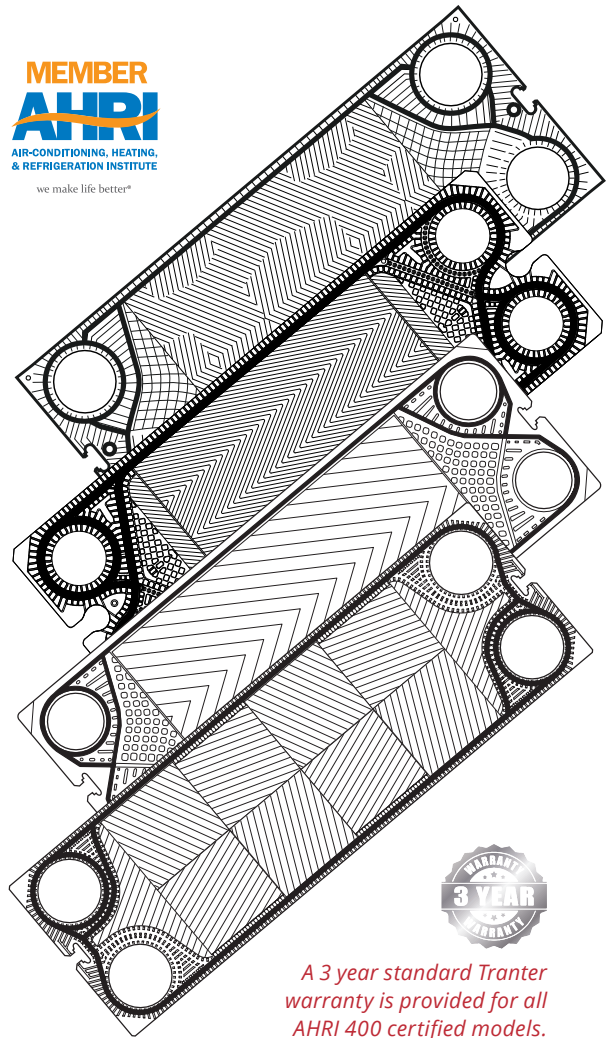

A 3 year standard Tranter warranty is provided for all AHRI 400 certified models.

ALSO WITHIN THE TRANTER PRODUCT RANGE

GFP Series

The GFP is a wide-gap heat exchanger. With plate gaps almost 1/2" wide, these plates are optimal for handling solids-laden streams that would easily plug a standard PHE. It boasts a large installed base in the ethanol industry for mash processing. It performs well in viscous applications or in the presence of fibers and is well suited for the pulp & paper, sugar, and chemical industries.

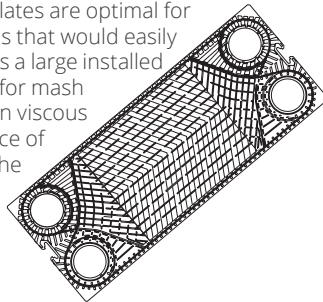

UXP Series

The UXP series has a tight pitch for higher heat transfer, and has corrugations in a traditional herringbone or chevron pattern. Steep and shallow angles are both available according to the requirements of the applications. It is most efficient with relatively clean solutions due to the greater induced turbulences within the flow stream.

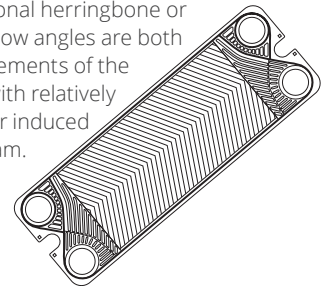

ADVANCED GASKET/BLEED PORT DESIGN

With Tranter's exclusive gasket/bleed port design, fluids will not intermix (other than a through-plate failure) when the plates are properly gasketed and the unit is assembled in accordance with prescribed instructions and design specifications.

Bleed ports convey boundary gasket leaks to the exterior, preventing intermixing.

